

TECHNICAL SHEET / SCHEDA TECNICA



# Proccopio

P6 Glycol system



**TEKNEITALIA®**

The Art of Quality



GELATO



## MEASURES/MISURE



FIG. 1

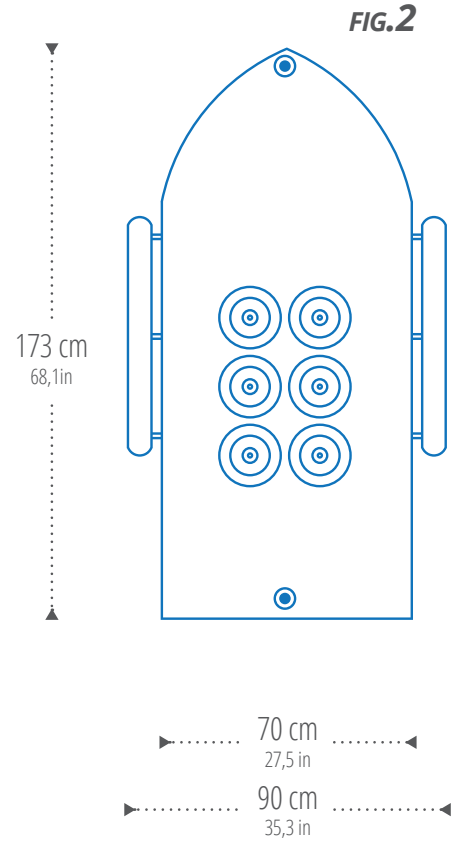



FIG. 2

## TECHNICAL SPECIFICATIONS

### CERTIFICATION

		
<b>EMPTY WEIGHT KG</b>	about 300	300 circa
<b>LOAD CAPACITY</b>	6+6 Stainless steel tubs (5kg each) total 60kg	8+6 carapine (5kg cad.) totale 60kg
<b>OPERATING COLD ROOM TEMPERATURE</b>	-25°/+5°C, -13°/+41° F	-25°/+5°C
<b>CLIMATE CLASS</b>	from 0° to 35°C	da 0° a 35°C
<b>COLD AUTONOMY</b>	6/7 hours	6/7 ore
<b>STANDARD FEATURE/DOTAZIONI STANDARD</b>		<b>5 KG STORAGE</b>
<b>BODY</b>	Painted aluminium	Alluminio verniciato
<b>OVERLAY</b>	Telescopic and removable tent in stainless steel	Tenda telescopica e smontabile in acciaio INOX
<b>LIGHTING</b>	Removable LED light in stainless steel	Plafoniera smontabile LED in acciaio INOX
<b>WORKTOP</b>	Stainless Steel	Acciaio INOX
<b>POWER SUPPLY</b>	240V/50Hz or 110V/60Hz	240V/50Hz oppure 110V/60Hz
<b>POWER CONSUMPTION</b>	450W	450W

Subject to technical modifications

Mezzo soggetto a modifiche tecniche



Glycol system



Models

Cooling System



Injected polyurethane without HCFC/CFC  
Glycol refrigeration  
Condensing hermetic system with motor fan,  
temperature control, copper evaporator  
-25°/+5°C  
from 0° to 35°C  
6/7 hours



PROCOPIO P6  
PROCOPIO P8  
PROCOPIO P3 SLIM  
PROCOPIO P4 SLIM  
PROCOPIO P4 XSLIM  
PROCOPIO P3 XSLIM  
DON COLA IN  
DON COLA FX  
DON GIOVANNI  
GEA IN  
ERMES

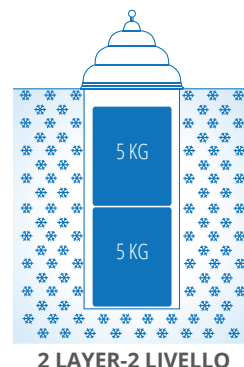

Poliuretano iniettato senza HCFC/CFC  
Refrigerazione a Glicole  
Sistema condensante ermetico con motoventilatore,  
controllo della temperatura, evaporatore in rame  
-25°/+5°C  
da 0° a 35°C  
6/7 ore



KATERINA P6  
KATERINA P8  
KATERINA P4 SLIM  
KATERINA P6 SLIM  
DON COLA OUT  
GEA OUT  
ERMES

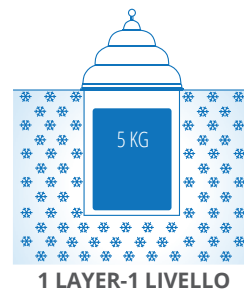

Dry convective system



Models



Injected polyurethane without HCFC/CFC  
Dry refrigeration  
Condensing hermetic system with motor fan,  
temperature control, copper evaporator  
-25°/+5°C  
from 0° to 35°C  
30 min



PROCOPIO V6  
PROCOPIO V9

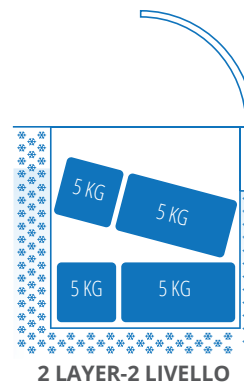

Poliuretano iniettato senza HCFC/CFC  
Refrigerazione a secco  
Sistema condensante ermetico con motoventilatore,  
controllo della temperatura, evaporatore in rame  
-25°/+5°C  
da 0° a 35°C  
30 min



KATERINA V6  
KATERINA V6 SLIM

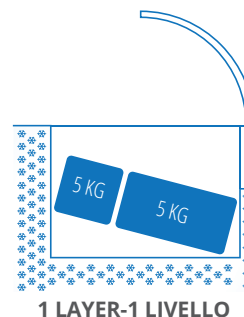

TECHNICAL SHEET / SCHEDA TECNICA



# Procoppio

Detachable bike system



# Katerina

Detachable bike system



**TEKNĒITALIA**<sup>®</sup>

The Art of Quality



GELATO





TECHNICAL SHEET / SCHEDA TECNICA



# Proccopio

P8 Glycol system



**TEKNEITALIA**<sup>®</sup>

The Art of Quality



GELATO



## MEASURES/MISURE

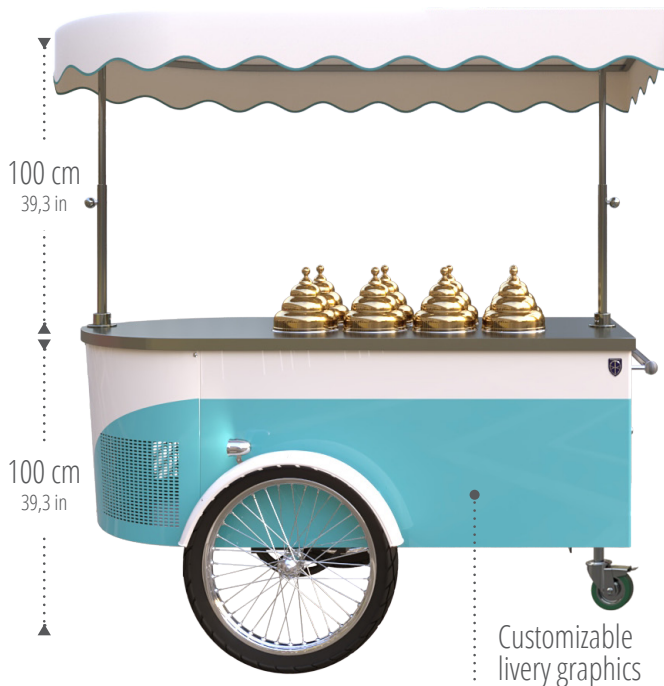

FIG. 1

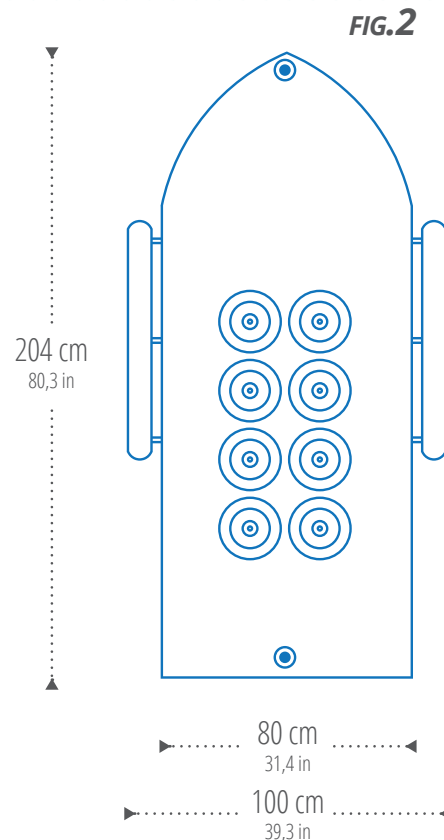



FIG. 2

## TECHNICAL SPECIFICATIONS

### CERTIFICATION

		
<b>EMPTY WEIGHT KG</b>	about 350	350 circa
<b>LOAD CAPACITY</b>	8+8 Stainless steel tubs (5kg each) total 80kg	8+8 carapine (5kg cad.) totale 80kg
<b>OPERATING COLD ROOM TEMPERATURE</b>	-25°/+5°C, -13°/+41° F	-25°/+5°C
<b>CLIMATE CLASS</b>	from 0° to 35°C	da 0° a 35°C
<b>COLD AUTONOMY</b>	6/7 hours	6/7 ore
<b>STANDARD FEATURE/DOTAZIONI STANDARD</b>		
<b>BODY</b>	Painted aluminium	Alluminio verniciato
<b>OVERLAY</b>	Telescopic and removable tent in stainless steel	Tenda telescopica e smontabile in acciaio INOX
<b>LIGHTING</b>	Removable LED light in stainless steel	Plafoniera smontabile LED in acciaio INOX
<b>WORKTOP</b>	Stainless Steel	Acciaio INOX
<b>POWER SUPPLY</b>	240V/50Hz or 110V/60Hz	240V/50Hz oppure 110V/60Hz
<b>POWER CONSUMPTION</b>	450W	450W

Subject to technical modifications

Mezzo soggetto a modifiche tecniche



**Glycol system**



**Models**

**Cooling System**



Injected polyurethane without HCFC/CFC  
Glycol refrigeration  
Condensing hermetic system with motor fan,  
temperature control, copper evaporator  
-25°/+5°C  
from 0° to 35°C  
6/7 hours



**PROCOPIO P6**  
**PROCOPIO P8**  
**PROCOPIO P3 SLIM**  
**PROCOPIO P4 SLIM**  
**PROCOPIO P4 XSLIM**  
**PROCOPIO P3 XSLIM**  
**DON COLA IN**  
**DON COLA FX**  
**DON GIOVANNI**  
**GEA IN**  
**ERMES**

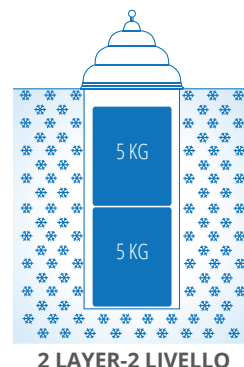

Poliuretano iniettato senza HCFC/CFC  
Refrigerazione a Glicole  
Sistema condensante ermetico con motoventilatore,  
controllo della temperatura, evaporatore in rame  
-25°/+5°C  
da 0° a 35°C  
6/7 ore



**KATERINA P6**  
**KATERINA P8**  
**KATERINA P4 SLIM**  
**KATERINA P6 SLIM**  
**DON COLA OUT**  
**GEA OUT**  
**ERMES**

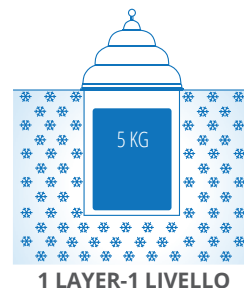

**Dry convective system**



**Models**



Injected polyurethane without HCFC/CFC  
Dry refrigeration  
Condensing hermetic system with motor fan,  
temperature control, copper evaporator  
-25°/+5°C  
from 0° to 35°C  
30 min



**PROCOPIO V6**  
**PROCOPIO V9**

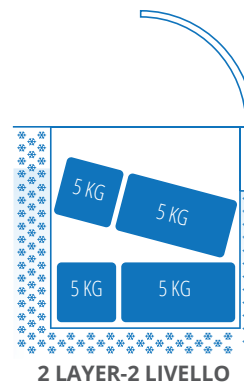

Poliuretano iniettato senza HCFC/CFC  
Refrigerazione a secco  
Sistema condensante ermetico con motoventilatore,  
controllo della temperatura, evaporatore in rame  
-25°/+5°C  
da 0° a 35°C  
30 min



**KATERINA V6**  
**KATERINA V6 SLIM**

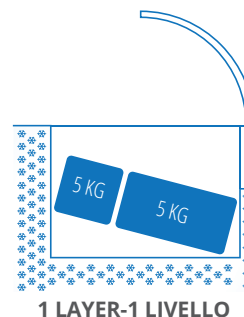

TECHNICAL SHEET / SCHEDA TECNICA



# Procoppio

Detachable bike system



# Katerina

Detachable bike system



**TEKNĒITALIA**<sup>®</sup>

The Art of Quality



GELATO

